

## THE 60 ORIENTATIONS OF THE 12 SIGILS AND THEIR 60x15=900 INTERCONNECTIONS

1- 3- 6- 12=60

1. In magical grimoires a *sigil* or *seal* is a symbol which carries occult meaning. It is a form of shorthand used to represent a spiritual being in pictorial form, or it can be a geometrical pattern which traces the letters of the name of the entity set against an invisible background of letters or numbers. Objects of power such as magical *talismans*, *amulets*, *phylacteries* and *lamens* also use *sigils*, but which must then be imbued with the intent of the user to fulfill their function.
2. In Saros philosophy, a *sigil* is defined as a 6-pointed unicursal shape\* that carries occult meaning, and joins six equidistant points in a circle, each point representing one of the six fundamental processes responsible for creation, and which are called the six “*constructors*”.
3. The six *constructors* are in fact all of the combinations of the three archetypal forces that exist in the divine world as expressions of the Will of the Holy One. They can be named as the: The *Active* (A), *Passive* (P), and *Neutralising* (N) forces\*\*.  
The constructors represent these three forces acting as a threesome to create the celestial and terrestrial worlds that we live in. As the three forces interact with one another, six swirlings are created between them: NPA, APN, PAN, NAP, ANP, PNA. Diagrammatically, the positions and names of the constructors are fixed and determined by the placement of the 3 forces.

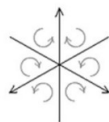

4. One possible set of names to express the qualities of the six swirlings is: *Initiate, Expand, Repeat, Contract, Receive, Transform*.  
Of course, other names are possible too. For instance in Kabbalah the six constructors would be named as the six sephiroth on the pillars of Force and Form: *Hockmah, Binah, Hesed, Gevurah, Nezach, Hod*, all of which surround and energise the trinity of *Kether, Tiphereth* and *Yesod* on the central column of Equilibrium, and all of which are reflected in The Presence, in the kingdom of *Malkuth*. In the *Sepher Yetzirah*, which was written before the traditional names of the sephiroth were formulated the six constructors could stand for three of the five boundless pairs of opposites, such as the boundless: *East, West, North, South, Above, Below*.
5. The One, the Three forces and the Six constructors set the foundation for ensuing creation. But what is needed for creation to proceed in a manner that is not entirely mechanical but capable of conscious evolution is a being that can be partly free of the above structure. Enter Man and Woman into the scene, beings capable of choice and who are able to bring about change through their actions, the fruits of their wisdom or ignorance. Perhaps it takes a human to set the wheels of conscious creation in motion!

## THE 60 ORIENTATIONS OF THE 12 SIGILS AND THEIR 60x15=900 INTERCONNECTIONS

As the six *constructors* stand at equidistant points from one another around The One - the centre of the circle-, we can imagine lines of interaction existing between them. If we choose the most economical patterns resulting only from those interactions that join all six *constructors* with a unicursal closed shape, we obtain the twelve *sigils*.

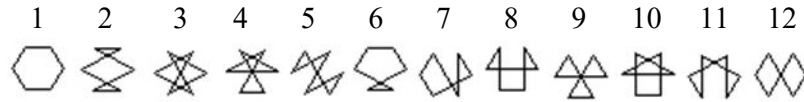

However, because these twelve *sigils* can also be mirrored or rotated there are in fact sixty possible shapes in total.

6. Let us now introduce the “*pair swapping*” rule, so that *sigils can change into one another in an orderly fashion*. So, if we now imagine that two of a *sigil*'s six points swap places with one another, then that *sigil*'s pattern will change into one of the other possible 60 *sigil* shapes. The fifteen possible pair swaps of the six constructors are: (1,2), (1,3), (1,4), (1,5), (1,6), (2,3), (2,4), (2,5), (2,6), (3,4), (3,5), (3,6), (4,5), (4,6), (5,6)

Why invent such a rule? Because even though creation could be said to happen all at once -so there is no time or space really-, to make sense of our world we have to be able to detach from it, and to also observe and examine it sequentially. If we assume that our mind can concentrate only on one object at a time, but that it also has the capacity to relate one object to another, because we possess memory and also have a sense of “I”, we are then capable of perceiving and identifying patterns, albeit in a personal and relative way. This ability to play and switch things around lies at the heart of the *pair swapping* rule.

7. The following pages show:
  - a) Which fifteen *sigil* shapes a typical *sigil* can change into by applying the “*pair swapping*” rule.  
*(I only show here the forms 1A to 12A, but all 60 sigil shapes had to be worked out to complete the table showing all 900 interactions.)*
  - b) A *mandala* pattern that all *sigils* share.
  - c) The table that summarises all 900 interconnections between the 60 *sigil* shapes
  - d) How we can organize all *sigils* into three major groups, based on their “*repeaters*”.

THE 60 ORIENTATIONS OF THE 12 SIGILS AND THEIR 60x15=900 INTERCONNECTIONS

Any sigil can change into 15 other sigil shapes by swapping a pair of its points

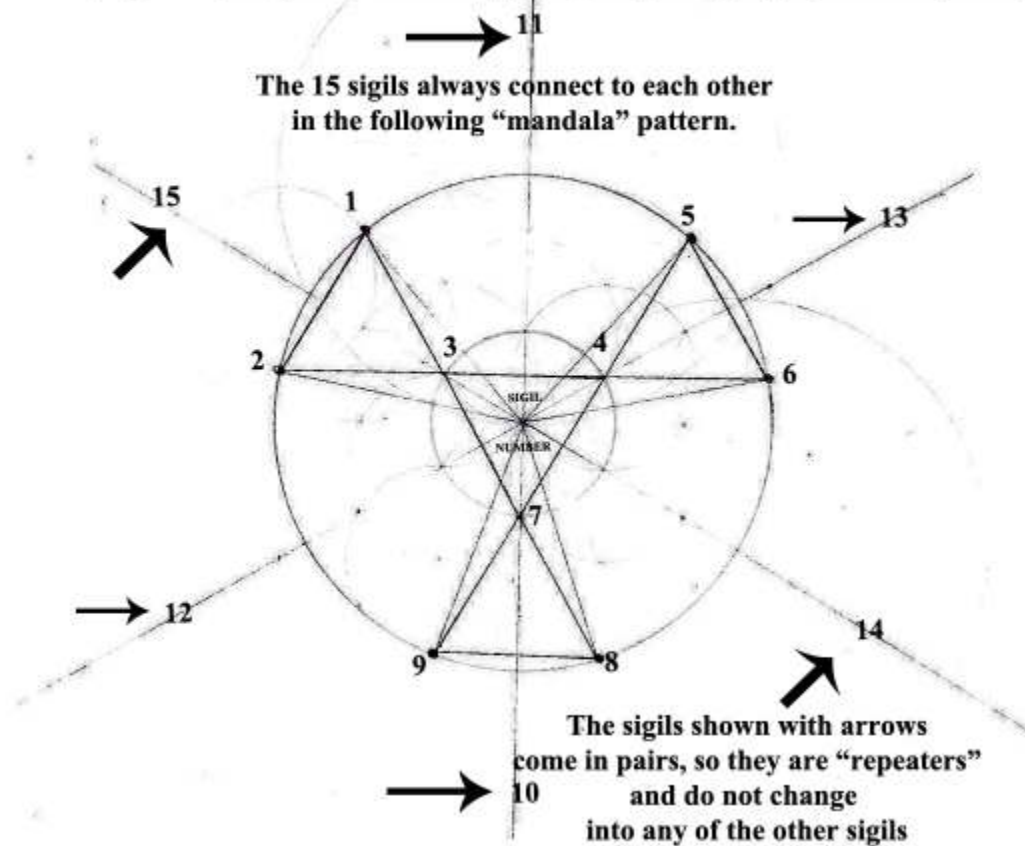

8. The numbering system devised for the 60 *sigil* shapes is very simple: First the twelve basic *sigils* are numbered from 1 to 12, as shown in point 5 above. (This is the same numbering system as that used in the Saros sigil booklet to identify the *sigils* of The Astrological Society's *septor*\*\*\*). Now as for their rotations and reflections which account for the 60 possible representations of the 12 *sigils*, there are five main categories: Sigil number 1 has only one representation, let us call it 1A. Sigil number 9 has two representations: 9A and 9B. Sigils number 2,3, and 12, have three representations each, hence we label sigil number 2 as: 2A, 2B, 2C. Similarly, there are 3A, 3B, 3C and 12A, 12B, 12C. Sigils number 4,5,6,8,10,11 have six possible orientations each, so for instance for sigil number 4 we have: 4A,4B, 4C, 4D, 4E, 4F. Finally sigil number 7 has 12 representations. We see these as: 12A, 12B, 12C, 12D, 12E, 12F, 12G,12H, 12I, 12J, 12K, 12L.

## THE 60 ORIENTATIONS OF THE 12 SIGILS AND THEIR 60x15=900 INTERCONNECTIONS

9. If we examine the information in the table at the end of this article which shows all 60 sigil shapes and their 900 interconnections with one another using the aforementioned “*pair swapping*” rule we can observe the following:

- The table depicts in bold three “repeater” sigils that every sigil can change into. These “repeaters” do not interact, change, into any of the other sigils. In the mandala diagrams shown, “repeaters” appear at the ends of the three single lines that pass through the centre of the *mandala*.
- If we organize all sigils according to their “repeaters” we see that there are 3 major groups:

Sigils 1 and 9 have as their “repeater” all orientations and reflections of sigil: 12  
Sigil 12 has as its “repeater” all orientations and reflections of sigils: 1 and 9

Sigils 3 and 5 have as their “repeater” all orientations and reflections of sigils:  
2 and 4

Sigils 2 and 4 have as their “repeater” sigils all orientations and reflections of  
sigils: 3 and 5

Sigils 7 and 11 have as their “repeater” all orientations and reflections of  
sigils: 6, 8, 10

Sigils 6, 8 and 10 have as their “repeater” all orientations and reflections of  
sigils: 7 and 11

-----  
\* In Wikipedia *unicursal* is defined as: “relating to or denoting a curve or surface which is closed and can be drawn or swept out in a single movement.”

\*\* In Saros philosophy the three forces have also been named “*the three mothers*”: Affirming, Denying and Unifying aspects of the Will of the One. The concept of a trinity underlying all levels of creation is ancient, and an improvement to dualistic ways of categorising the world. It can be found in most spiritual traditions in the East and West. So, for instance, in Judaism we have the three mother letters: Aleph, Mem and Shin. In Taoism there is: Yin, Yang and Taichi. In Christianity there is the holy trinity: Father, Son and Holy Ghost, in Hinduism there is Brahma, Shiva and Vishnu.

\*\*\*A *septor* is a unique sequence of 12 *sigils*, usual drawn around a circle, and arranged so that each of them can change into both the one before and the one after, using the “pair swapping” rule.

**THE 60 ORIENTATIONS OF THE 12 SIGILS AND THEIR 60x15=900 INTERCONNECTIONS**

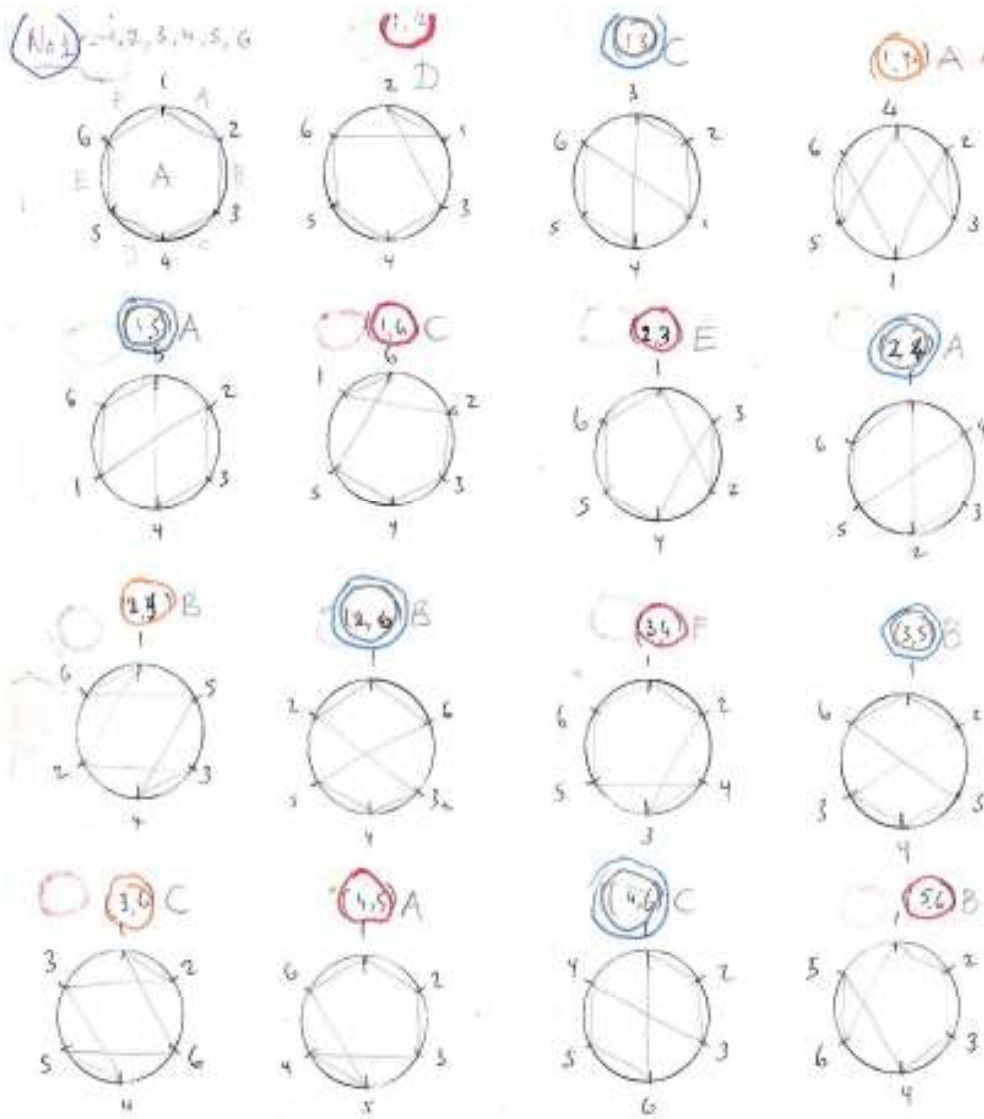

$1 \rightarrow 6 \times 6, 6 \times 10, 3 \times 21$



**THE 60 ORIENTATIONS OF THE 12 SIGILS AND THEIR 60x15=900 INTERCONNECTIONS**

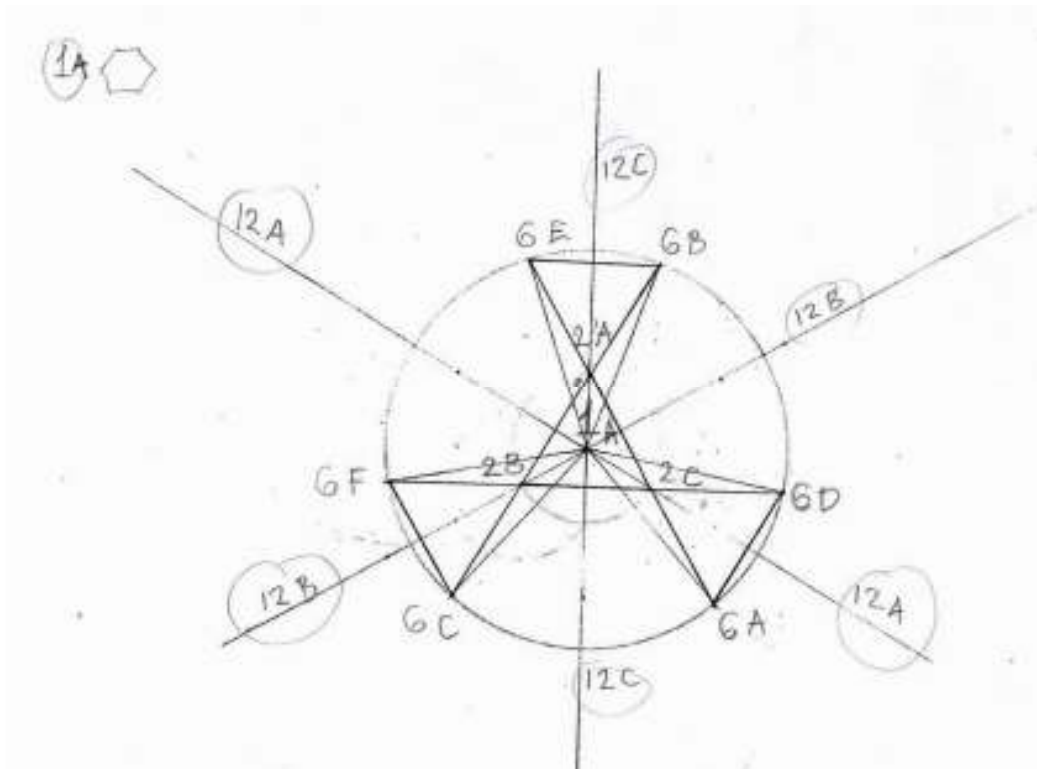

**THE 60 ORIENTATIONS OF THE 12 SIGILS AND THEIR 60x15=900 INTERCONNECTIONS**

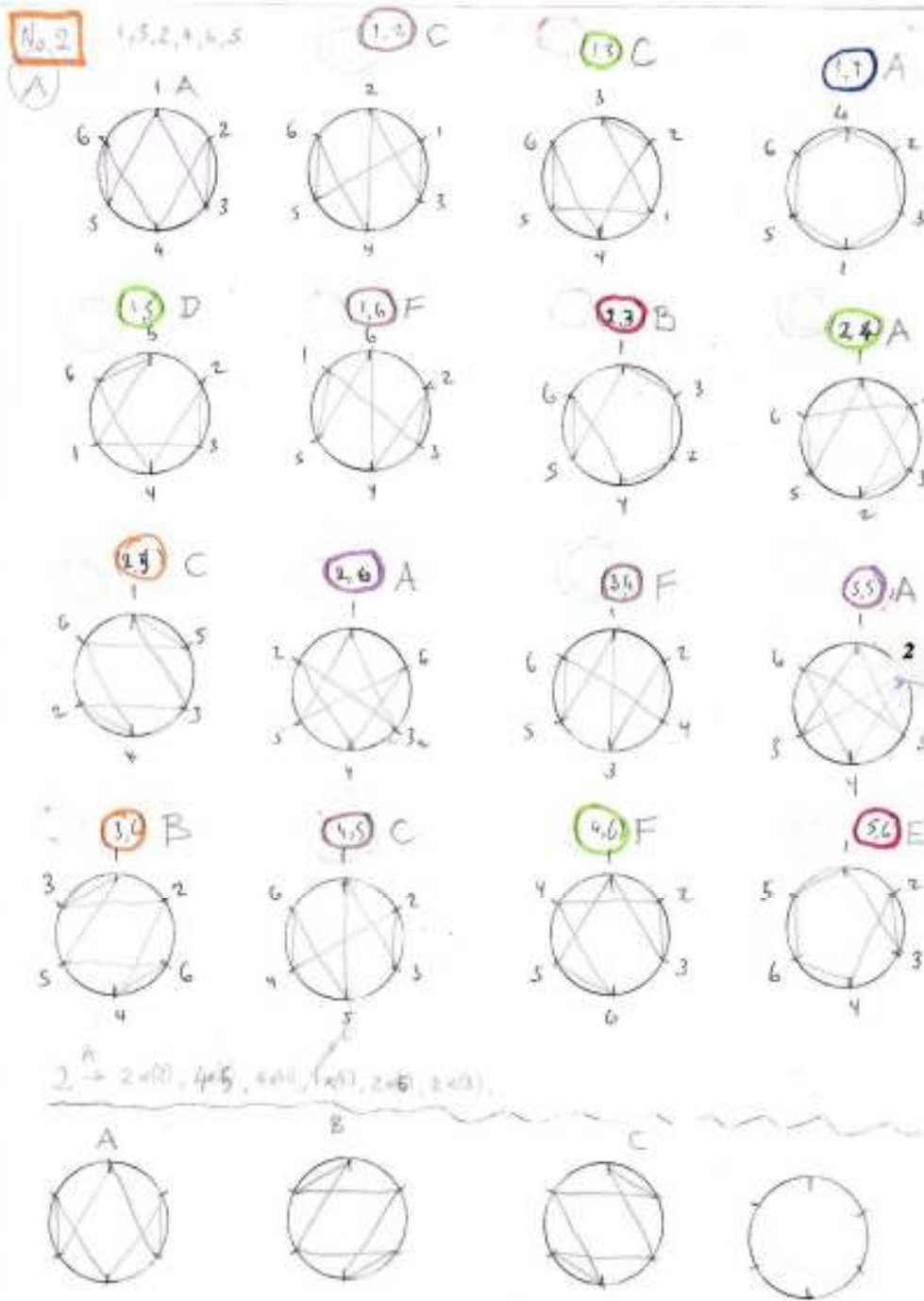

**THE 60 ORIENTATIONS OF THE 12 SIGILS AND THEIR 60x15=900 INTERCONNECTIONS**

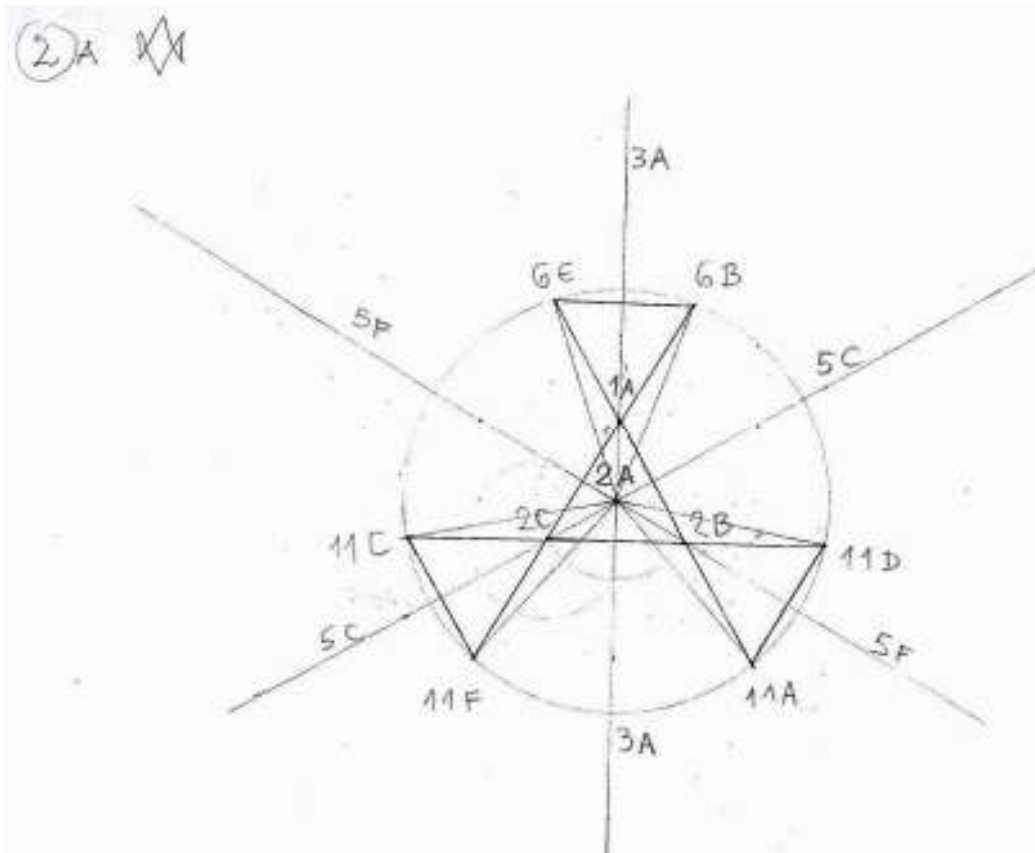



**THE 60 ORIENTATIONS OF THE 12 SIGILS AND THEIR 60x15=900 INTERCONNECTIONS**

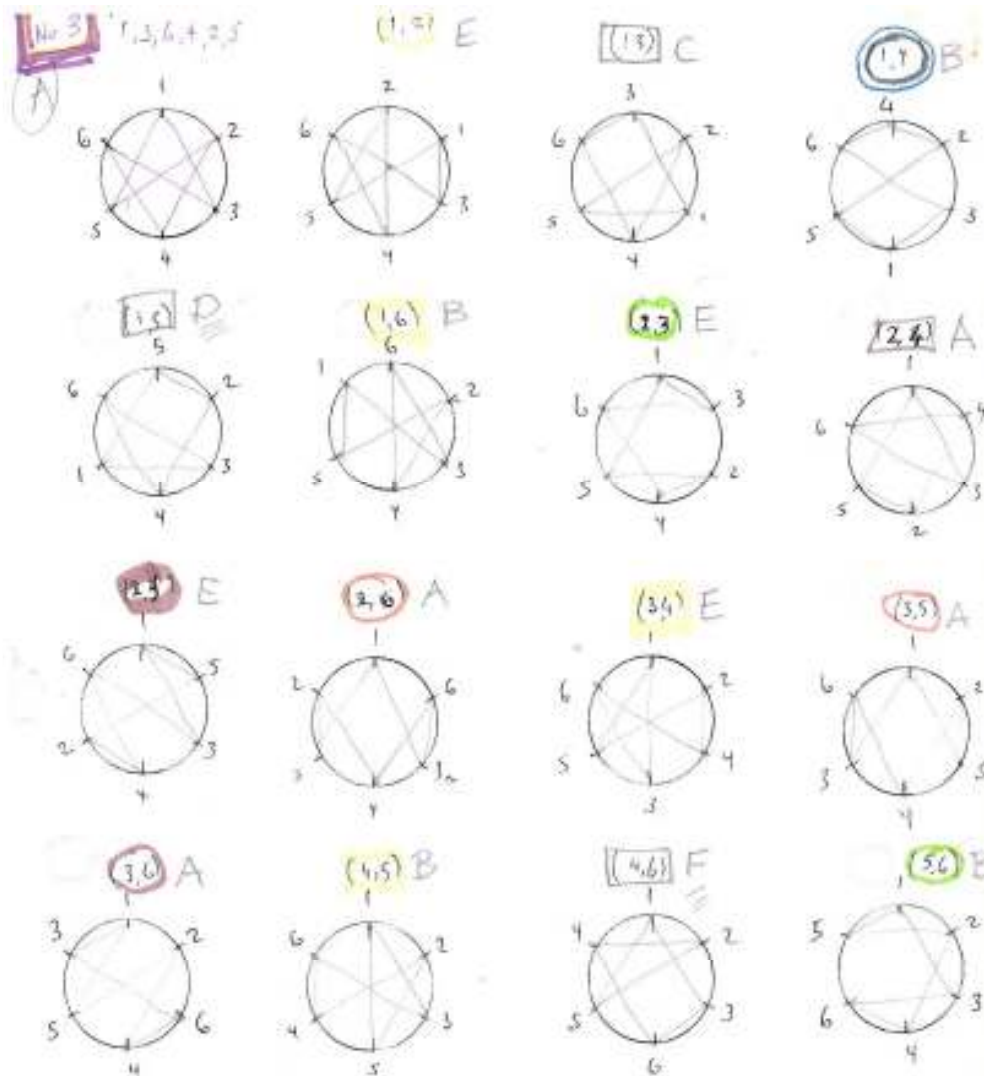

3 → 4x(4), 4x(6), 1x(1), 2x(2), 2x(5), 2x(6)

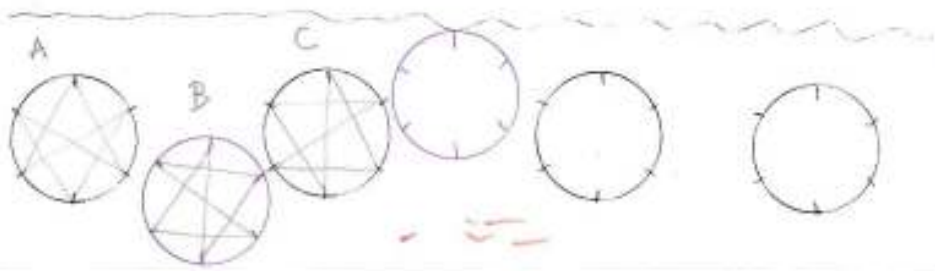

**THE 60 ORIENTATIONS OF THE 12 SIGILS AND THEIR 60x15=900 INTERCONNECTIONS**

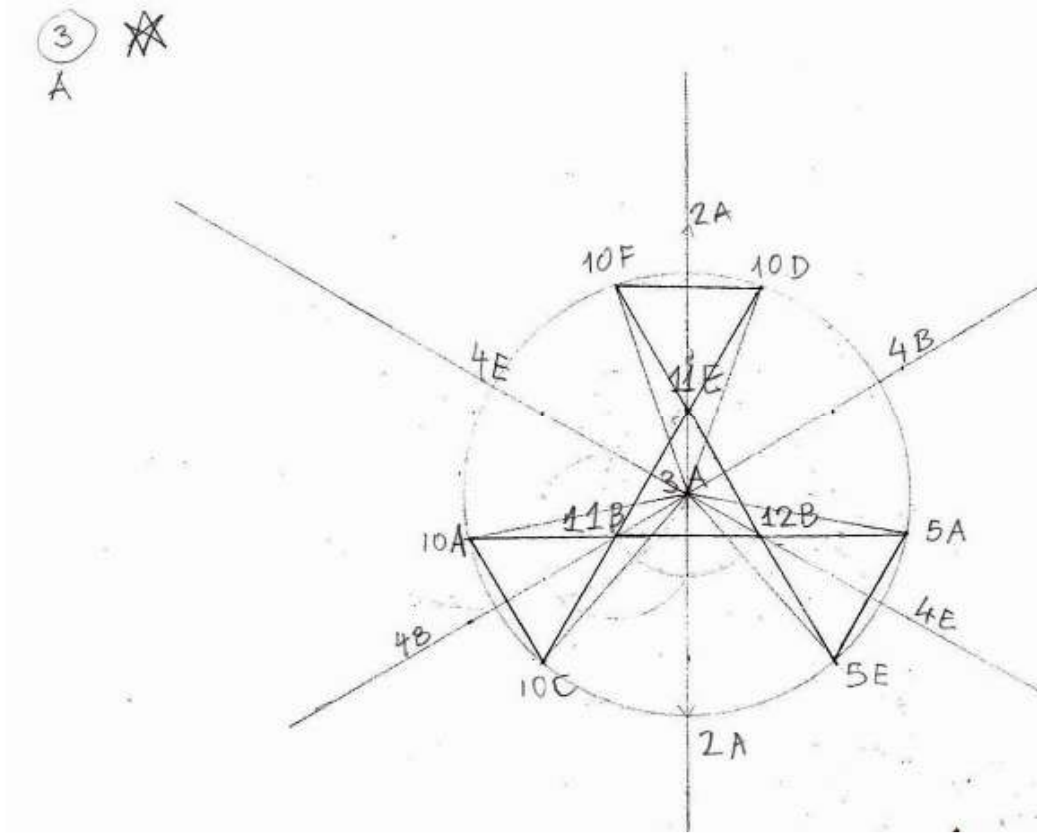

**THE 60 ORIENTATIONS OF THE 12 SIGILS AND THEIR 60x15=900 INTERCONNECTIONS**

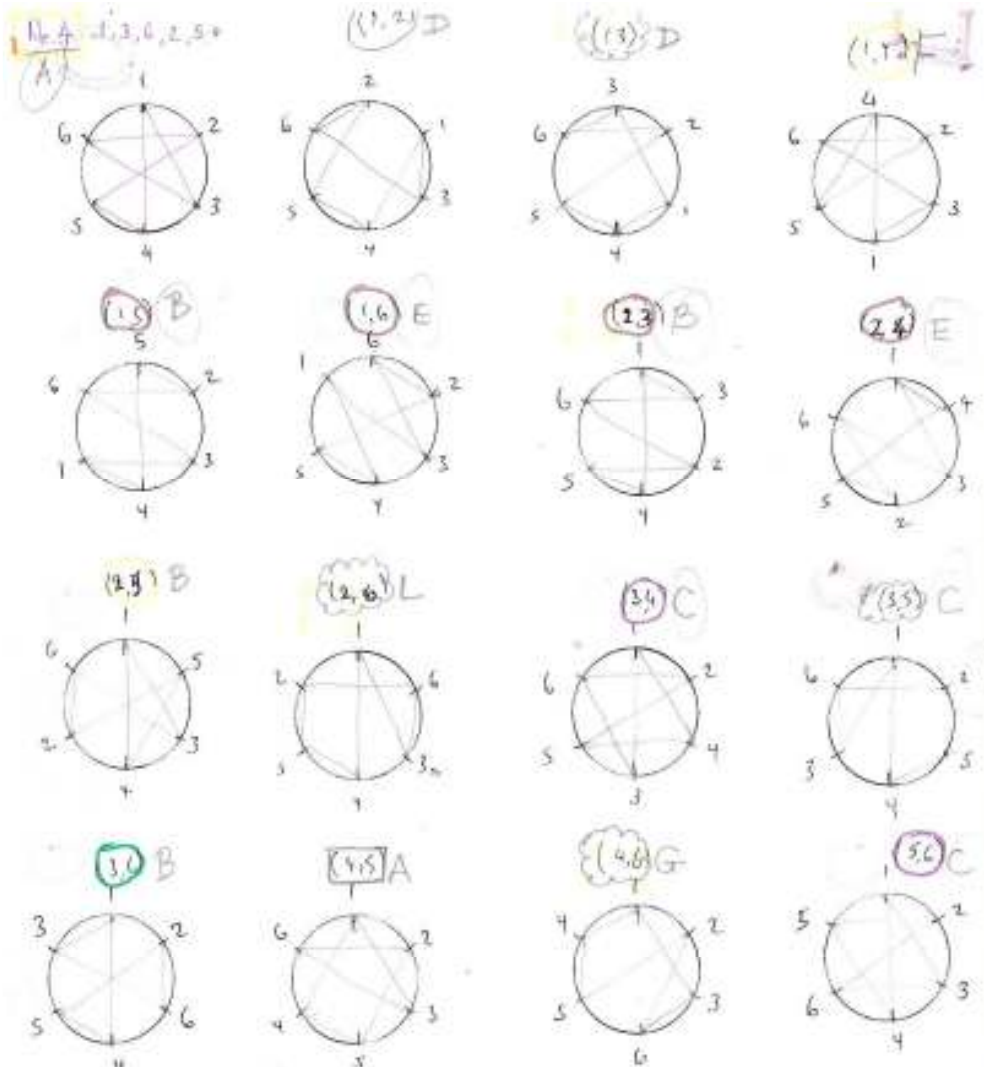

4 → (1x8), (1x7), (2x5), (4x5), (2x3), (1x4), (1x10)

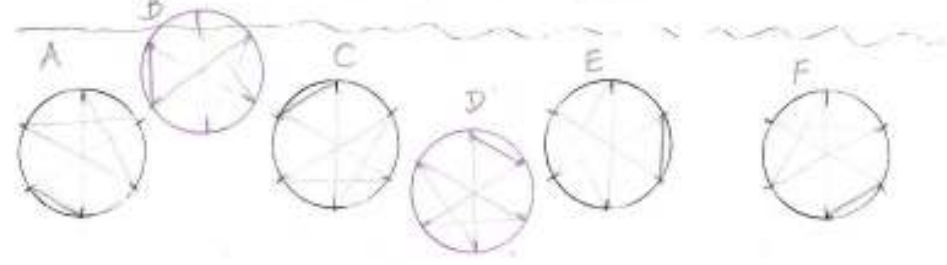

**THE 60 ORIENTATIONS OF THE 12 SIGILS AND THEIR 60x15=900 INTERCONNECTIONS**

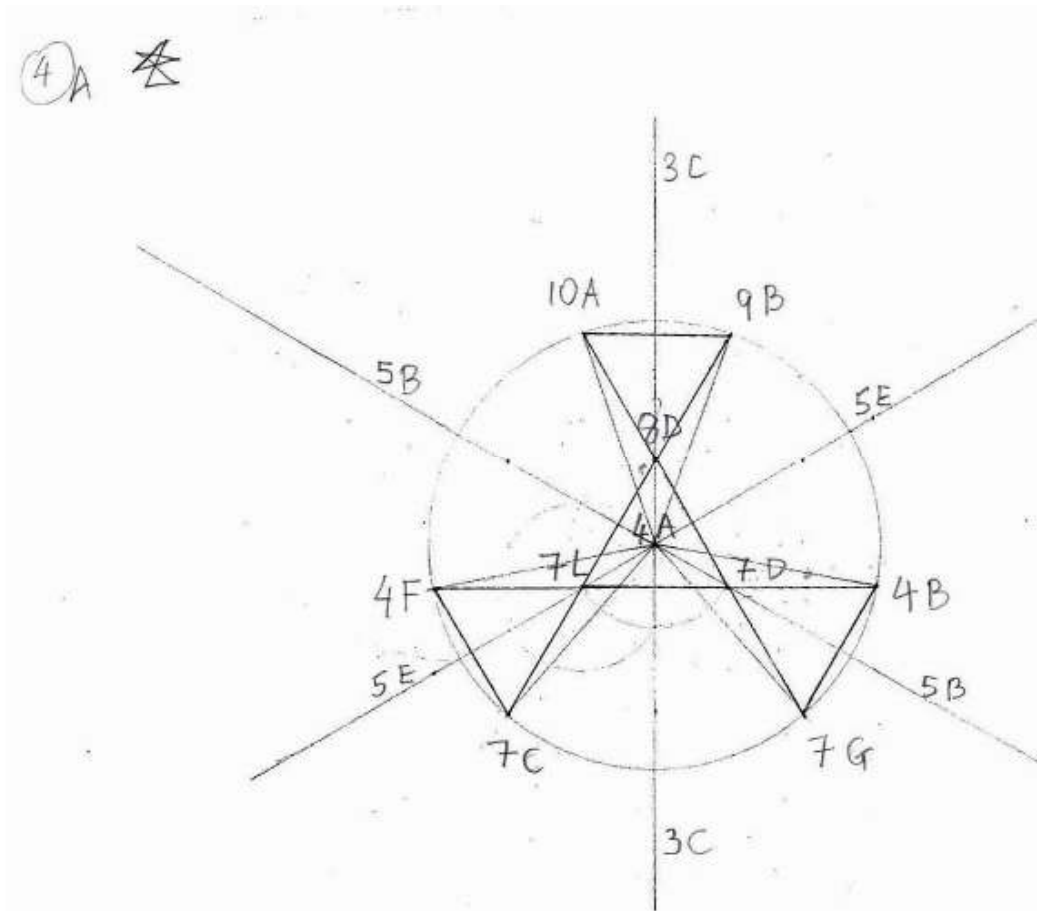

**THE 60 ORIENTATIONS OF THE 12 SIGILS AND THEIR 60x15=900 INTERCONNECTIONS**

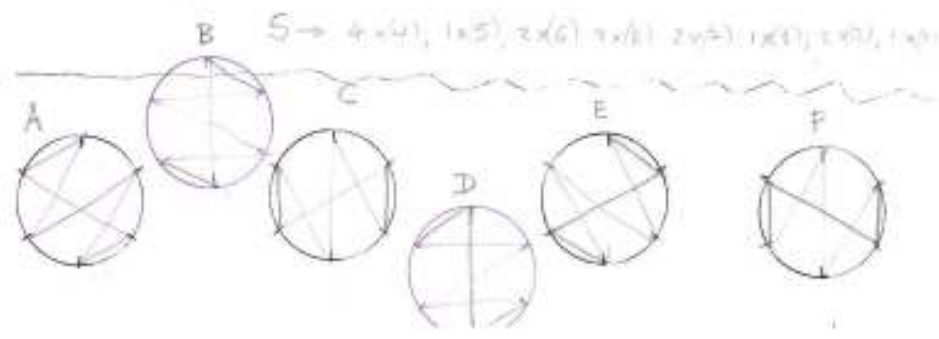
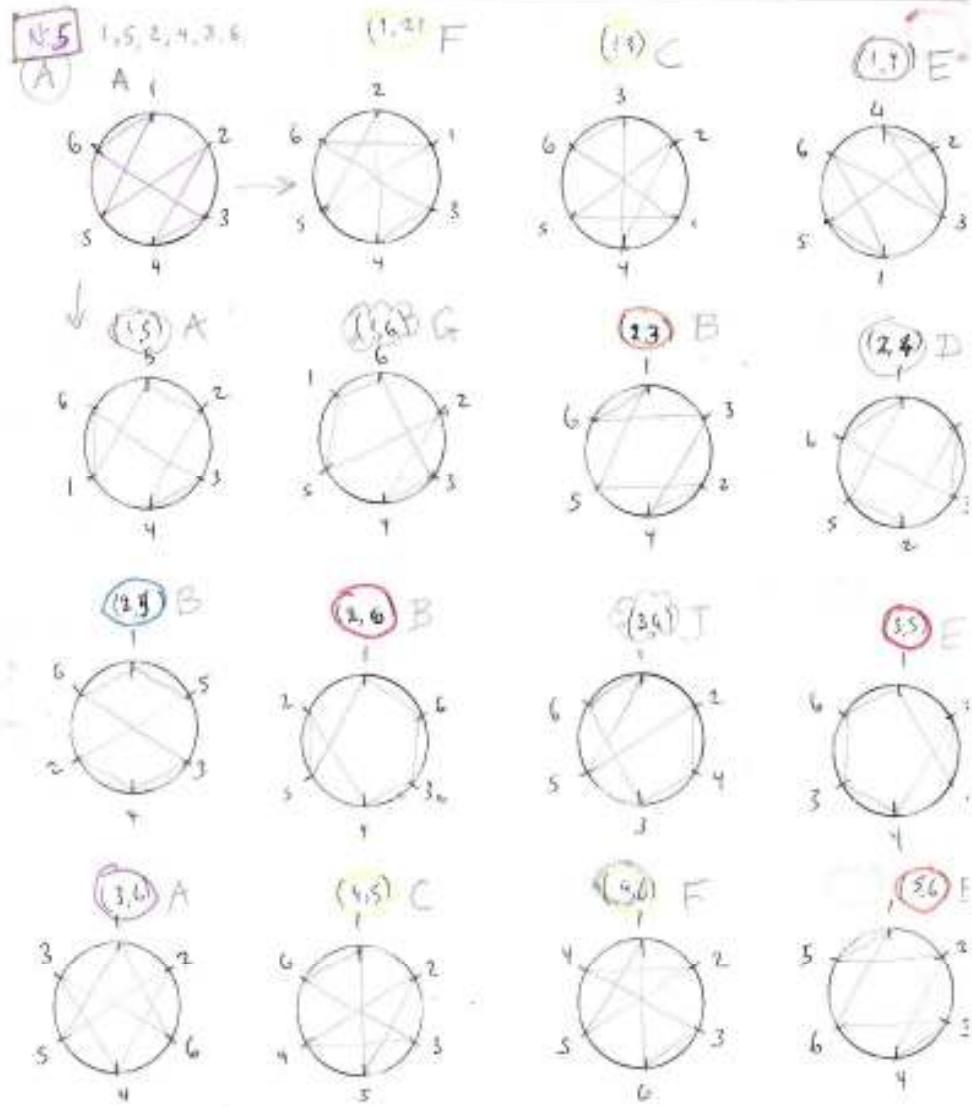

**THE 60 ORIENTATIONS OF THE 12 SIGILS AND THEIR 60x15=900 INTERCONNECTIONS**

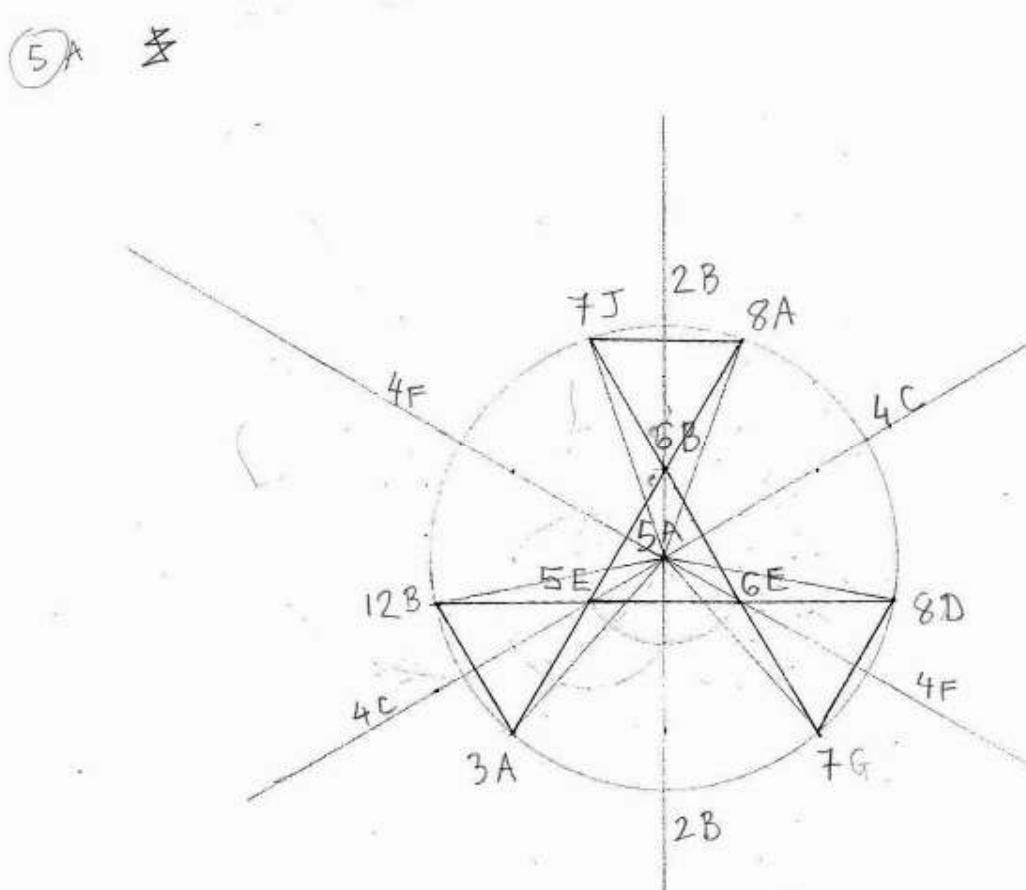

**THE 60 ORIENTATIONS OF THE 12 SIGILS AND THEIR 60x15=900 INTERCONNECTIONS**

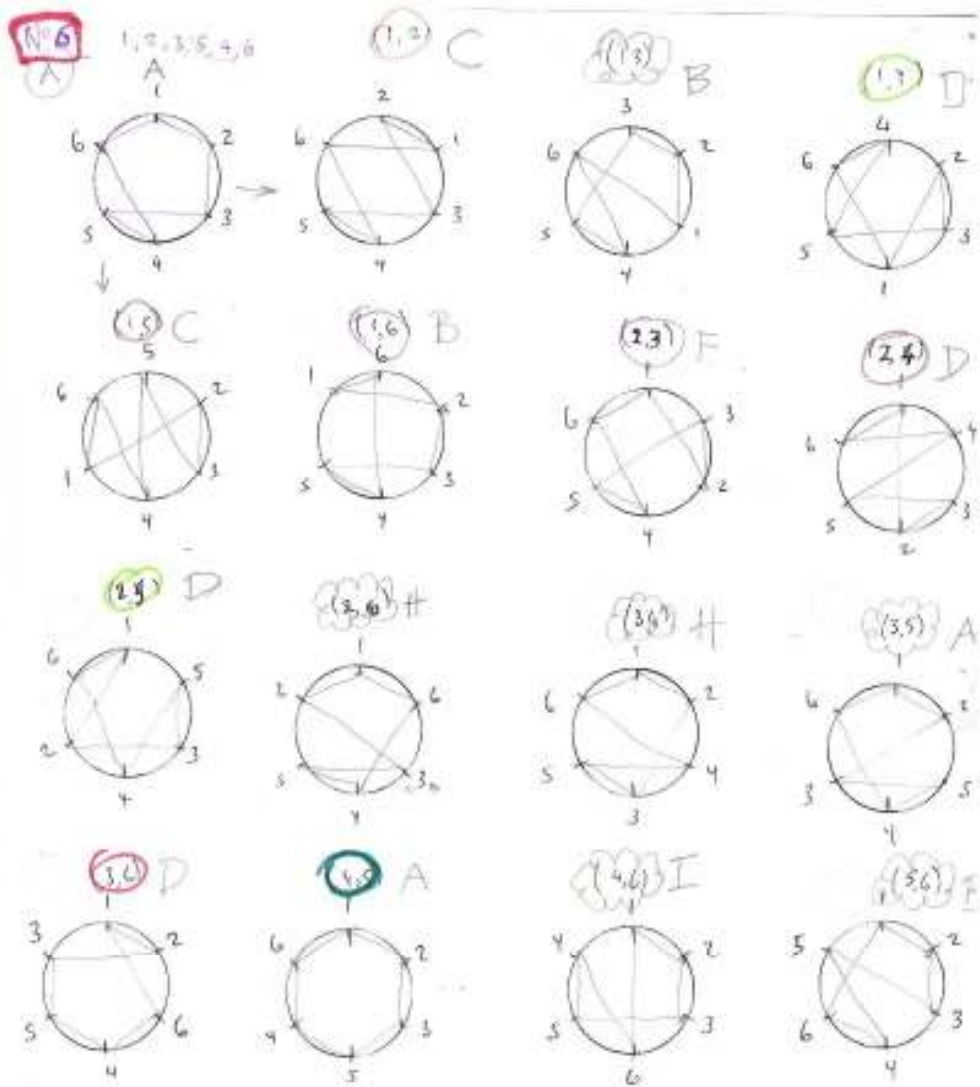

$G \rightarrow 1(1), 1x(2), 2x(1), 2x(2), 2x(3), 6x(2), 1x(6)$

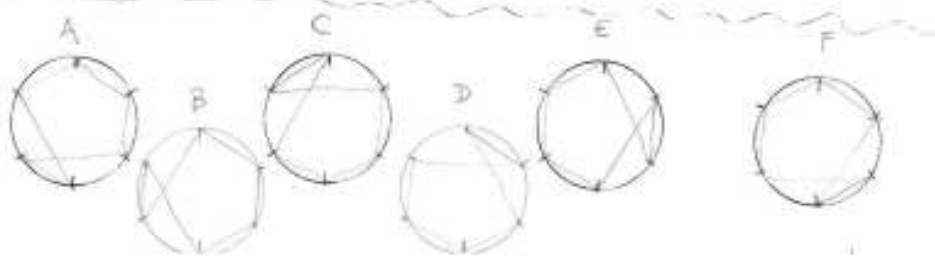

**THE 60 ORIENTATIONS OF THE 12 SIGILS AND THEIR 60x15=900 INTERCONNECTIONS**

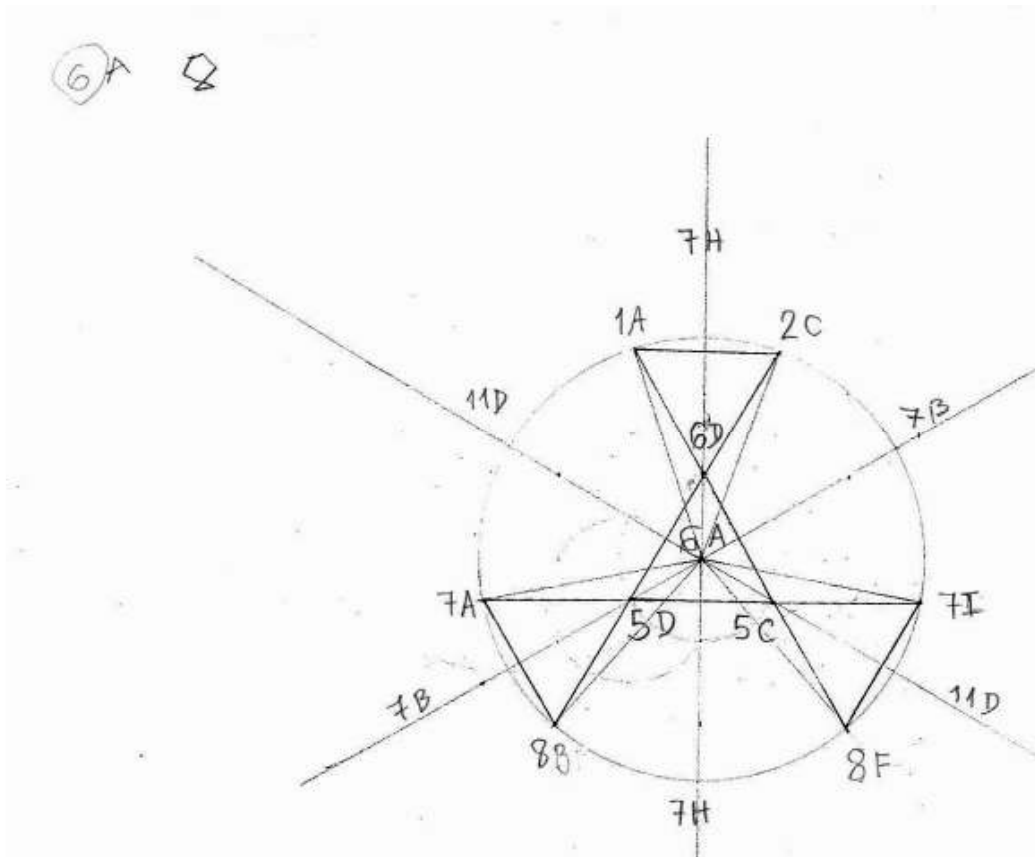



**THE 60 ORIENTATIONS OF THE 12 SIGILS AND THEIR 60x15=900 INTERCONNECTIONS**

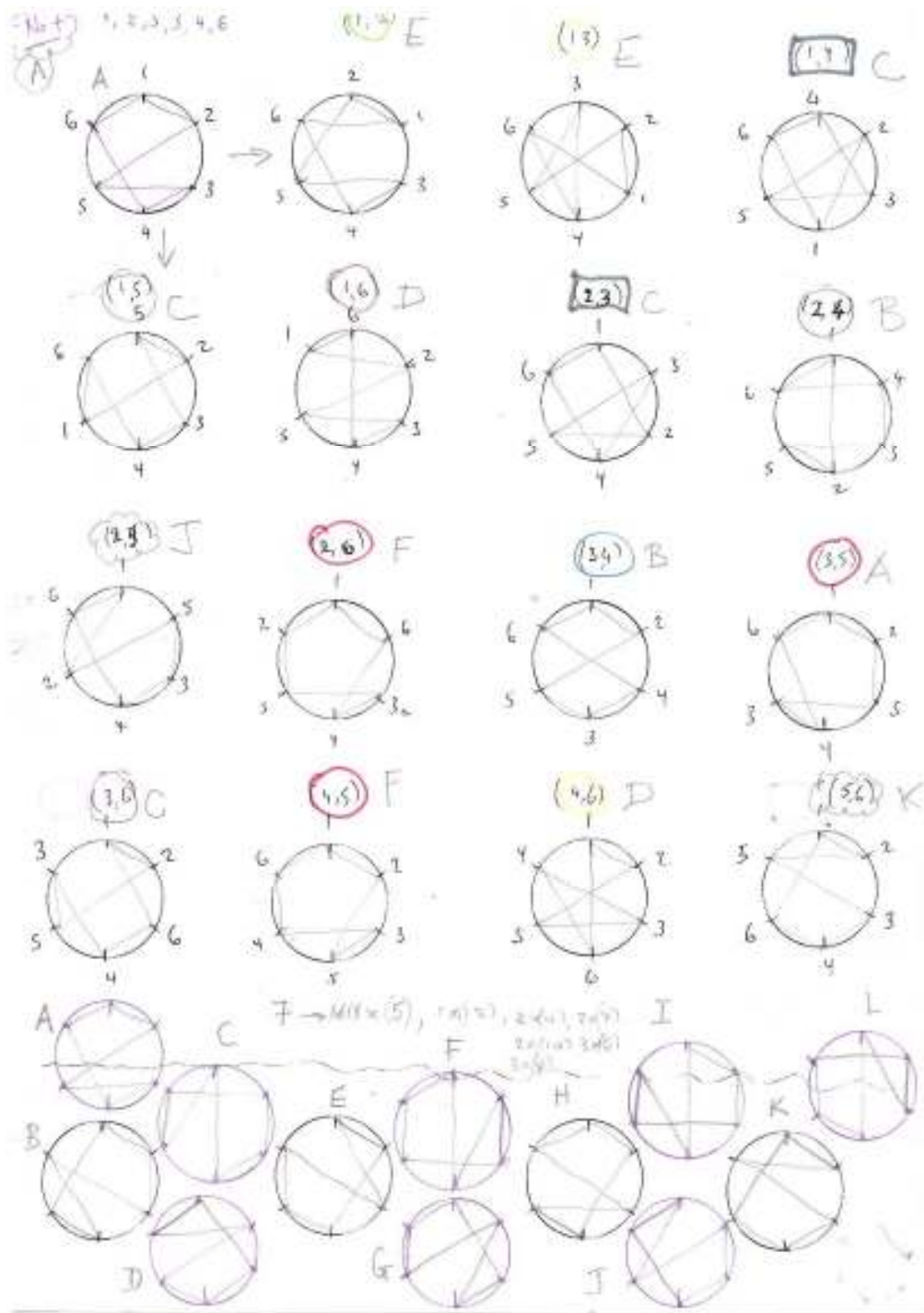

**THE 60 ORIENTATIONS OF THE 12 SIGILS AND THEIR 60x15=900 INTERCONNECTIONS**

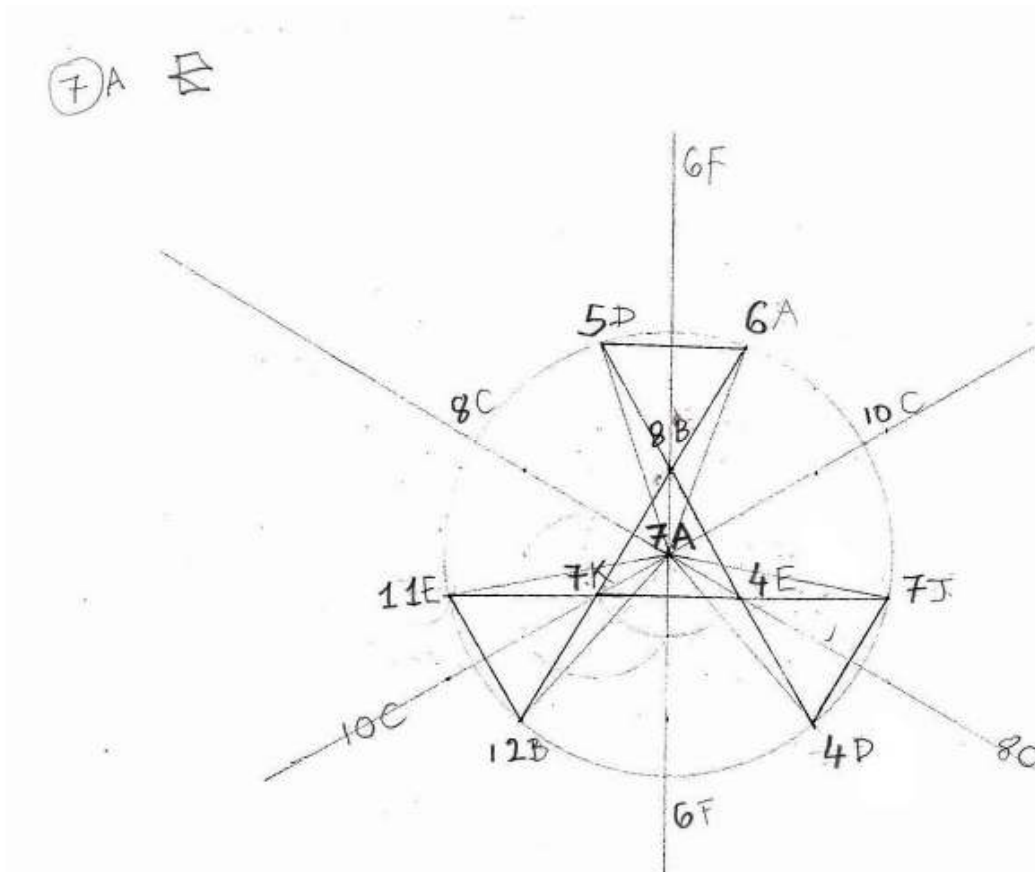

**THE 60 ORIENTATIONS OF THE 12 SIGILS AND THEIR 60x15=900 INTERCONNECTIONS**

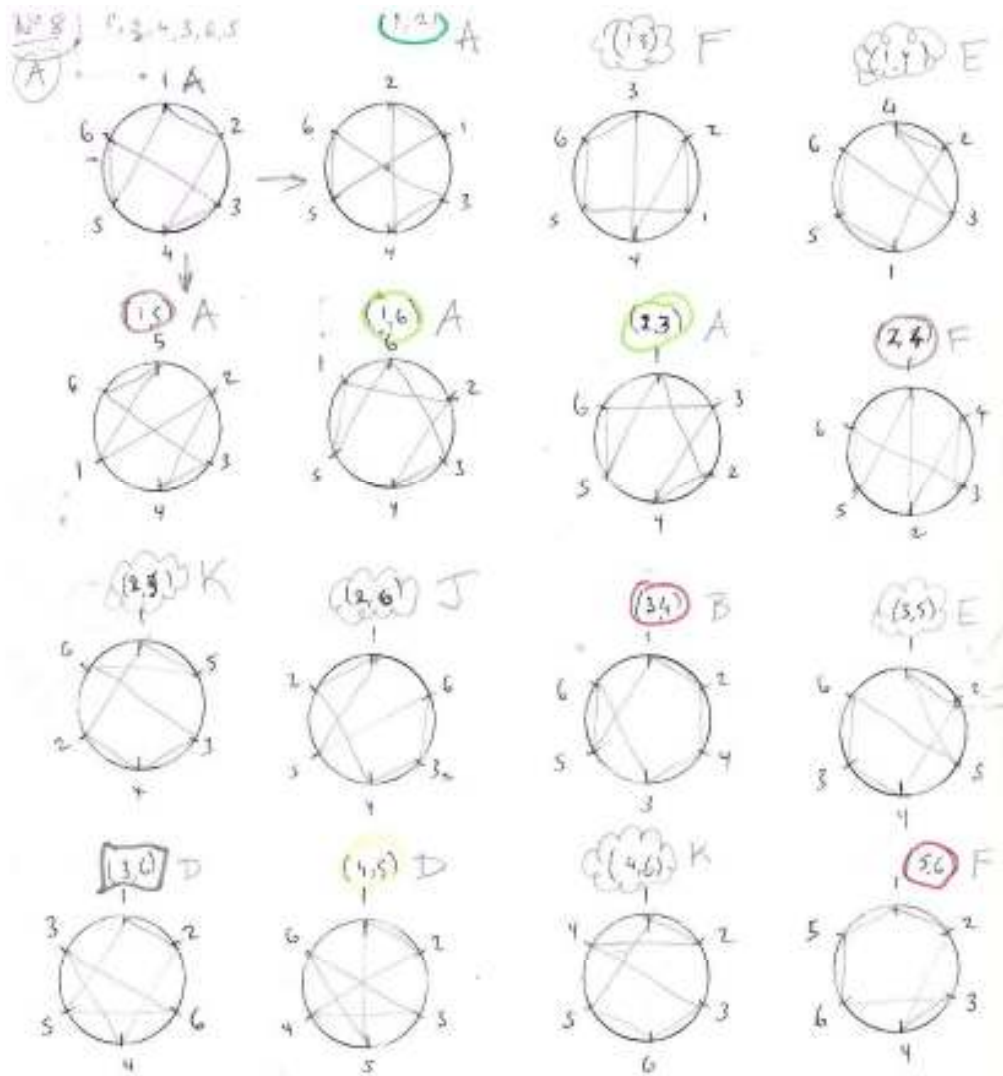

$\delta \rightarrow 1 \times (4), 1 \times (4), 1 \times (4), 2 \times (5), 2 \times (5), 4 \times (6), 2 \times (6)$

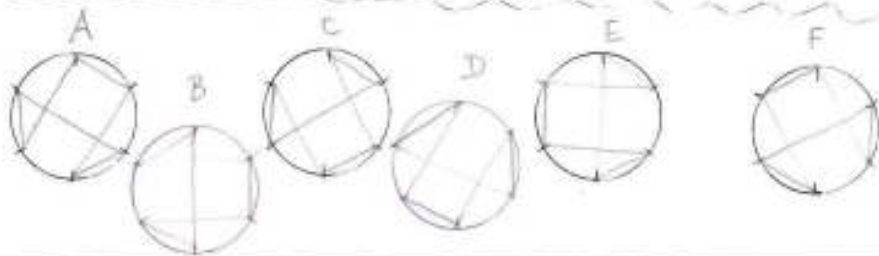

**THE 60 ORIENTATIONS OF THE 12 SIGILS AND THEIR 60x15=900 INTERCONNECTIONS**

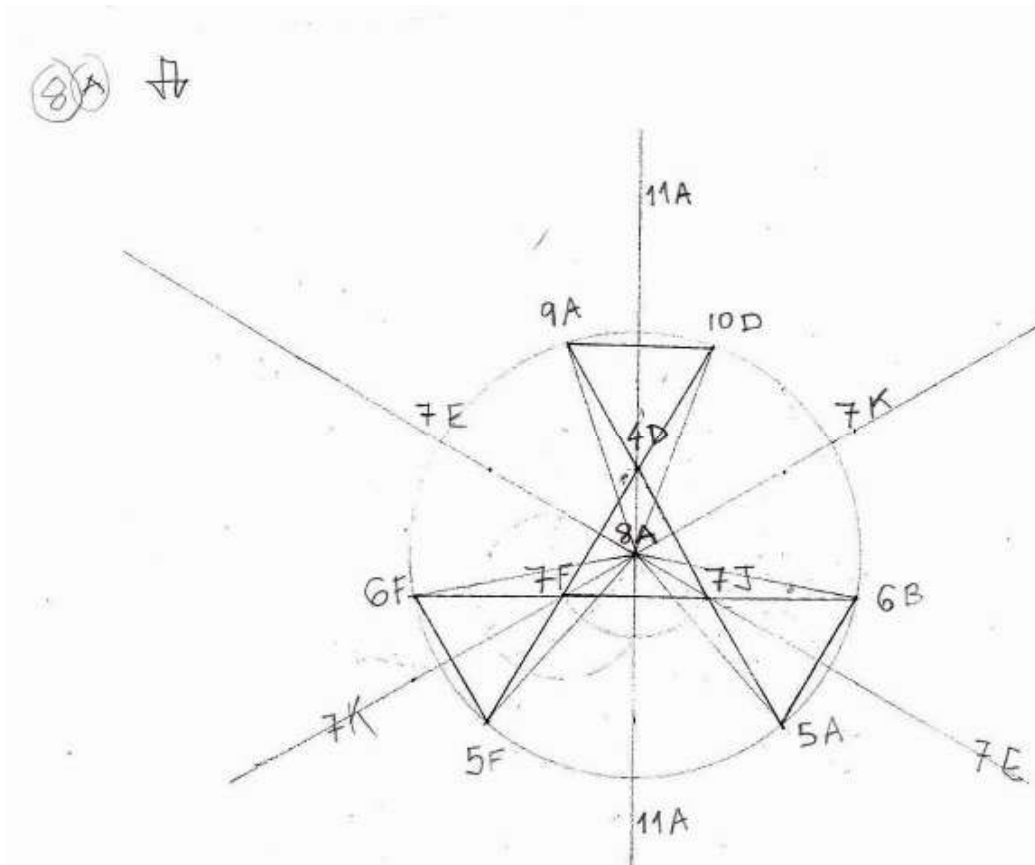

**THE 60 ORIENTATIONS OF THE 12 SIGILS AND THEIR 60x15=900 INTERCONNECTIONS**

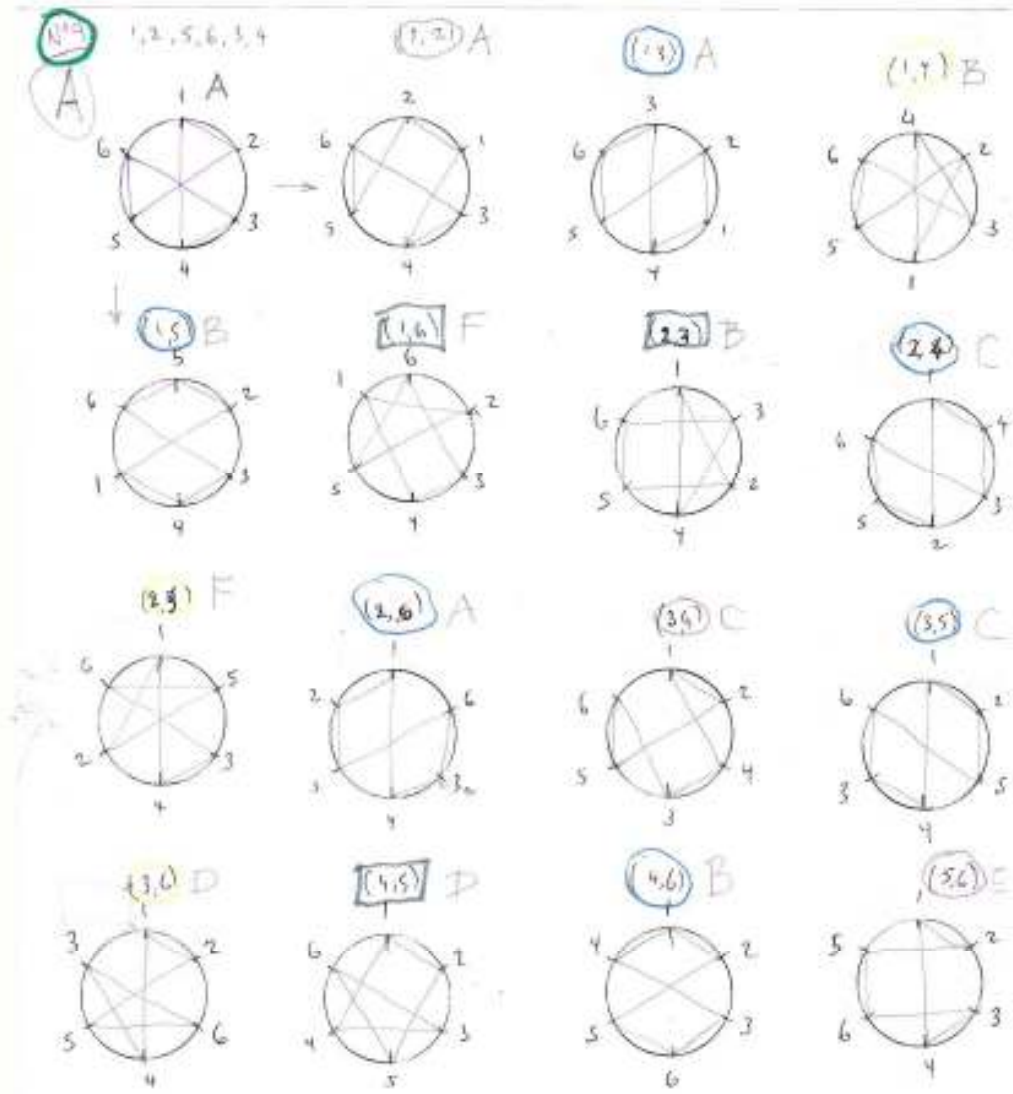

9 → 6x(12), 3x(10), 3x(4) 3x(6)



**THE 60 ORIENTATIONS OF THE 12 SIGILS AND THEIR 60x15=900 INTERCONNECTIONS**

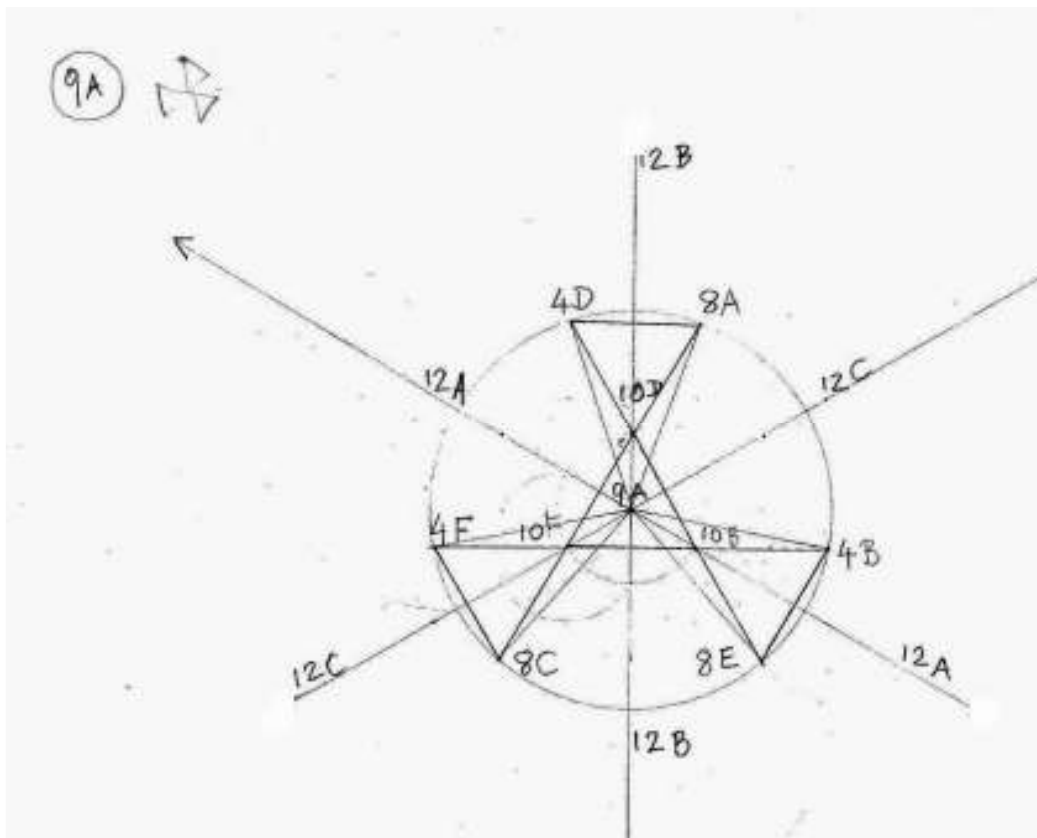

**THE 60 ORIENTATIONS OF THE 12 SIGILS AND THEIR 60x15=900 INTERCONNECTIONS**

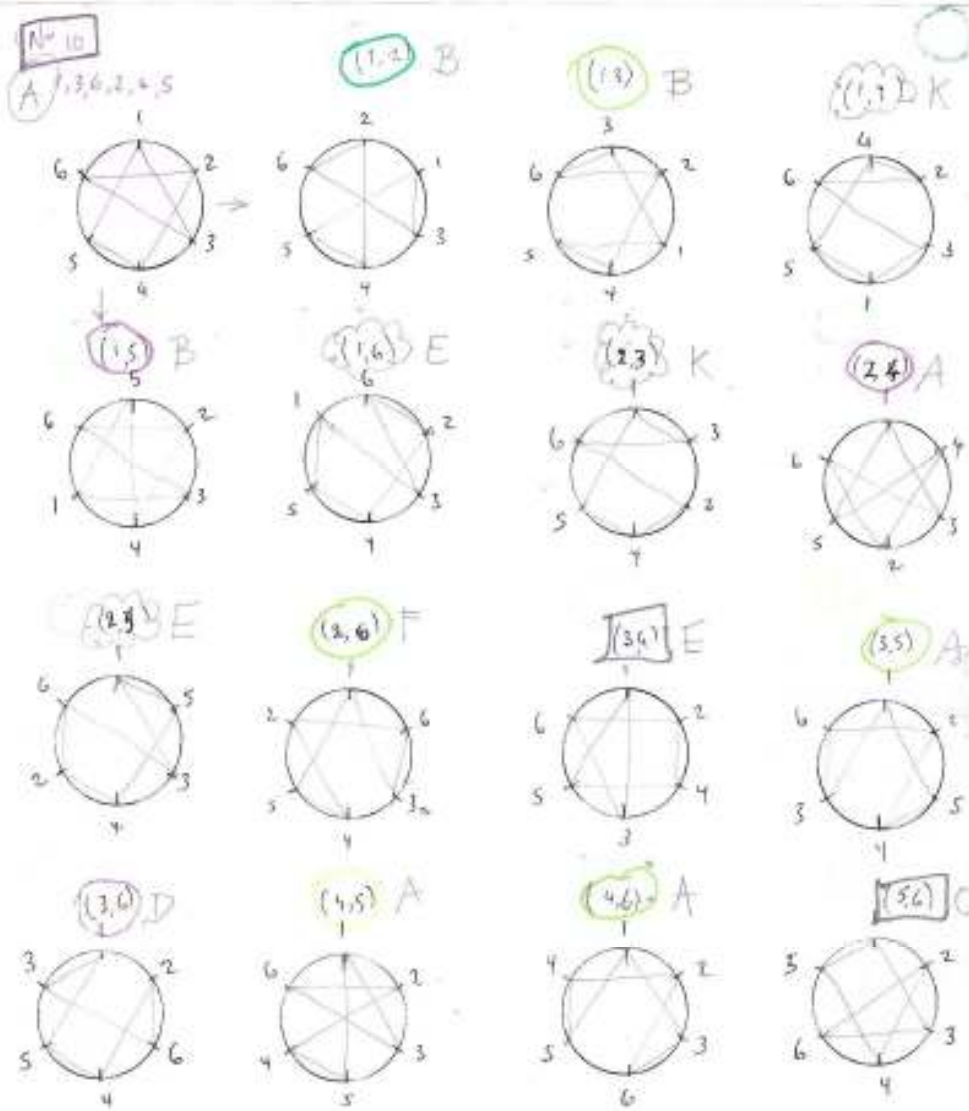

10 → 1x(1), 1x(2), 1x(3), 2x(4), 3x(5), 4x(6), 4x(7), 4x(8)

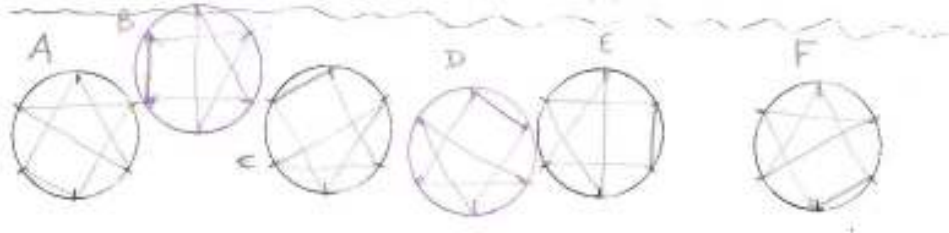

**THE 60 ORIENTATIONS OF THE 12 SIGILS AND THEIR 60x15=900 INTERCONNECTIONS**

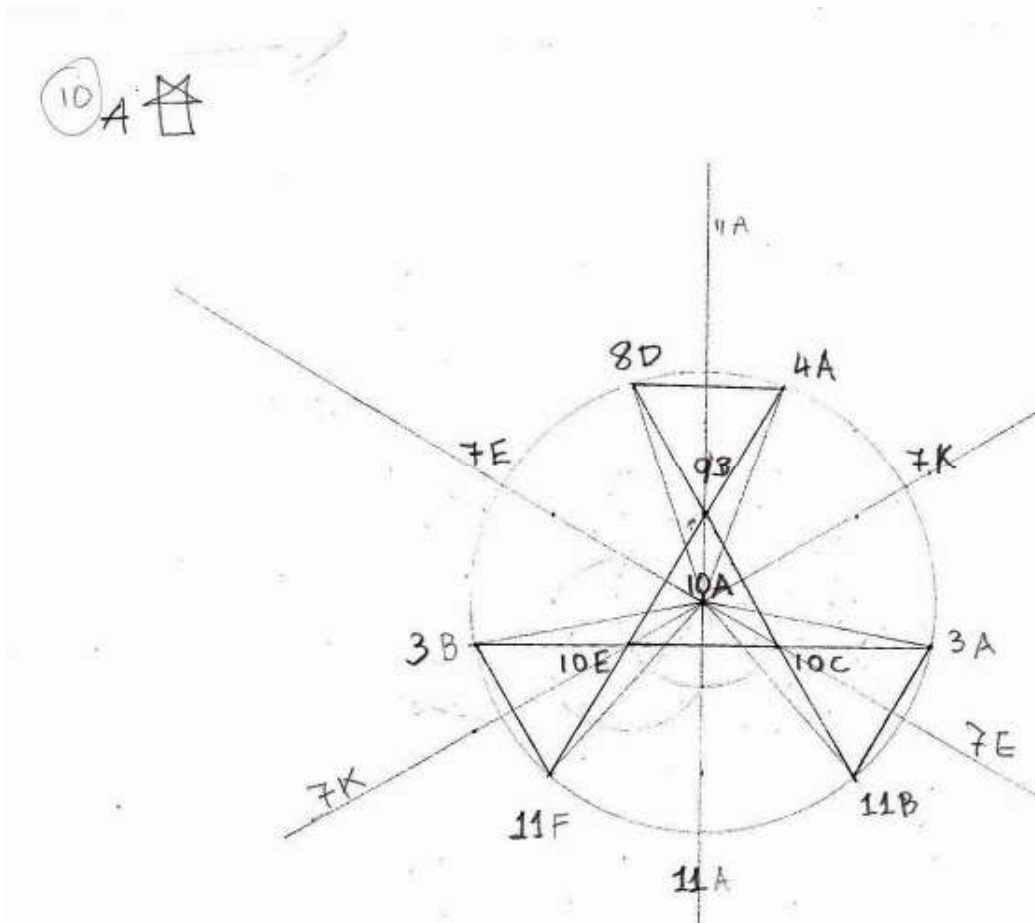



**THE 60 ORIENTATIONS OF THE 12 SIGILS AND THEIR 60x15=900 INTERCONNECTIONS**

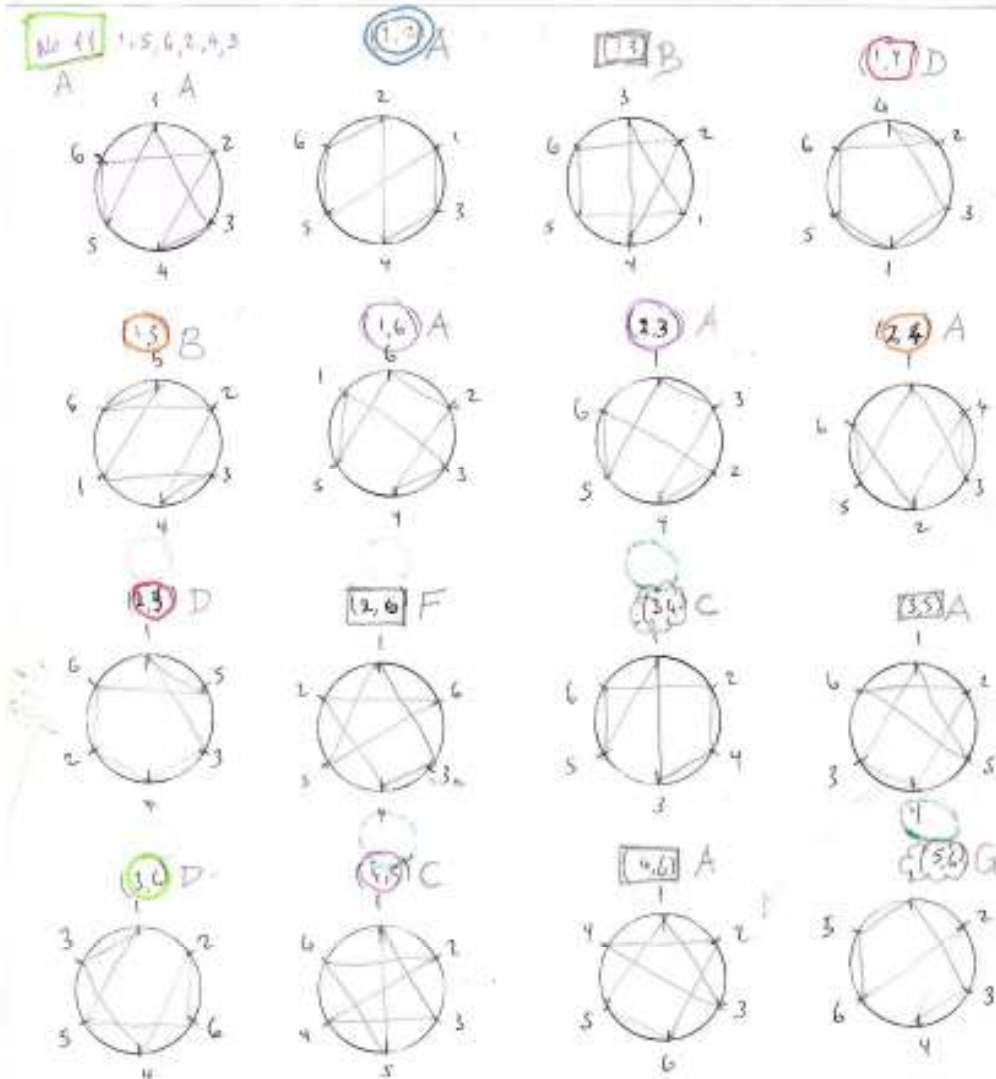

11 → 1(1) 1(1) 4(1) 2(4) 2(1) 2(1) 2(1) 2(1) 2(1)

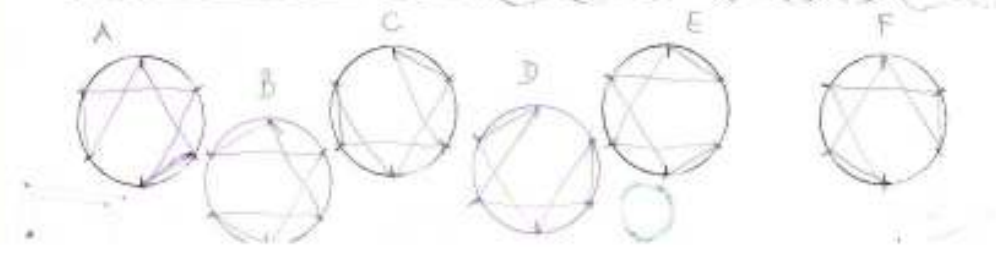

**THE 60 ORIENTATIONS OF THE 12 SIGILS AND THEIR 60x15=900 INTERCONNECTIONS**

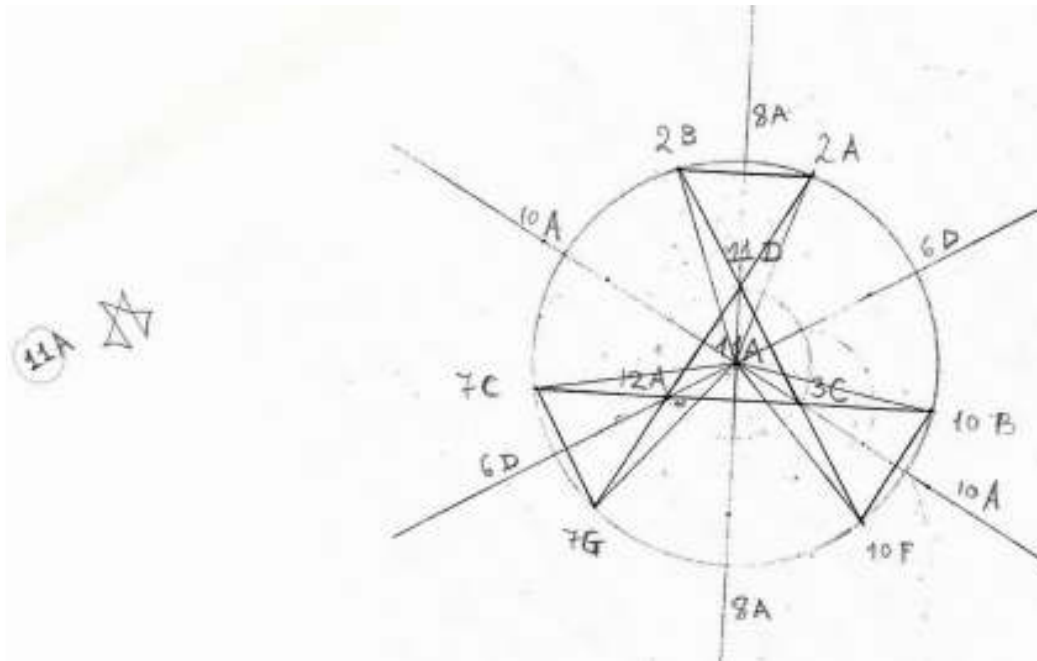

**THE 60 ORIENTATIONS OF THE 12 SIGILS AND THEIR 60x15=900 INTERCONNECTIONS**

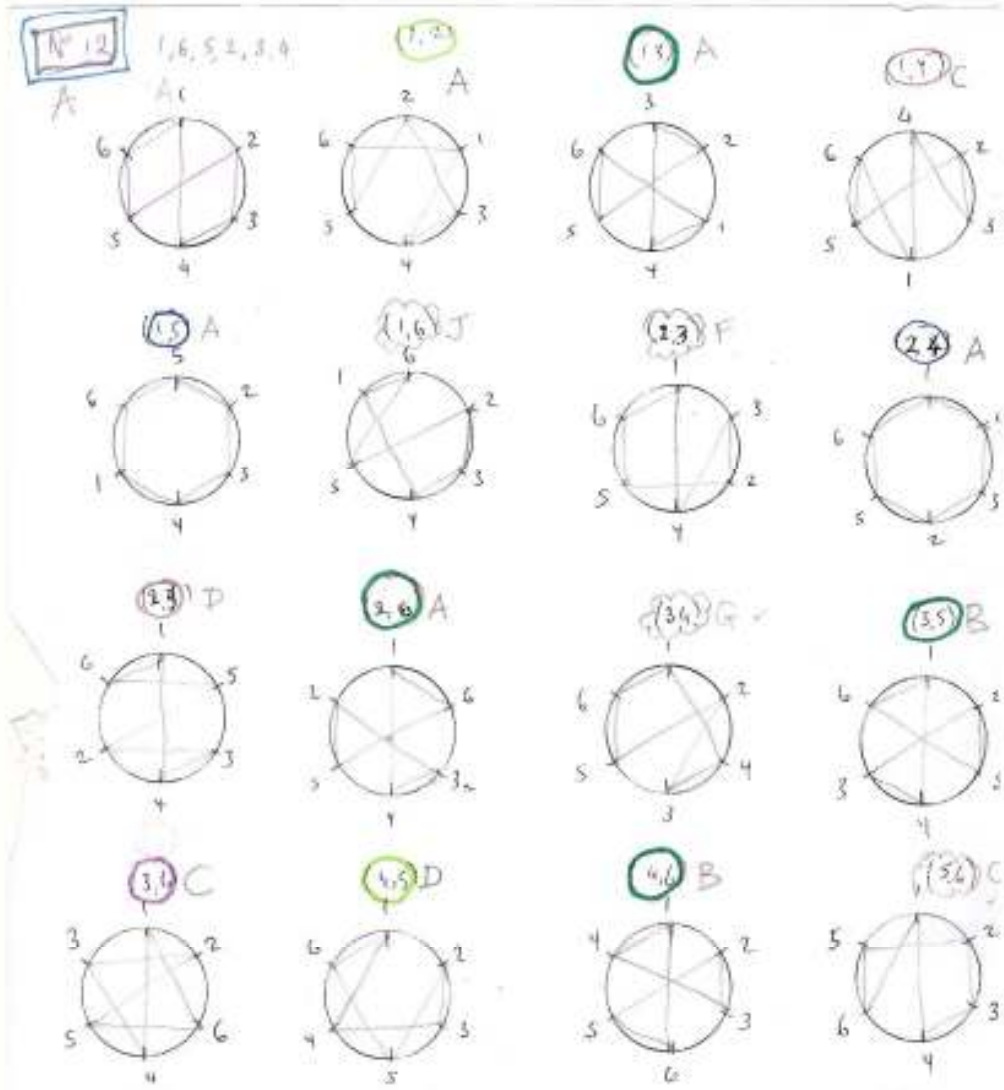

12 → 2x(11) 4x(11) 2x(5) 2x(11) 6x(7) 1x(3)

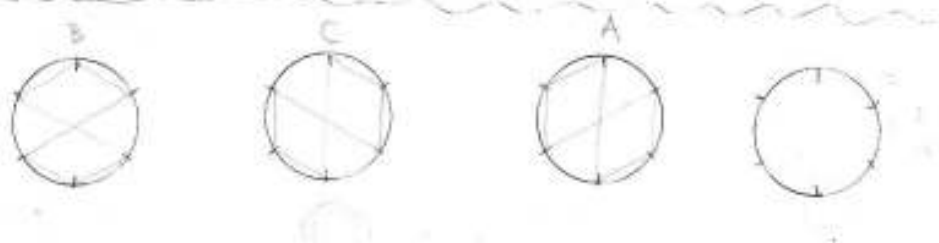

**THE 60 ORIENTATIONS OF THE 12 SIGILS AND THEIR 60x15=900 INTERCONNECTIONS**

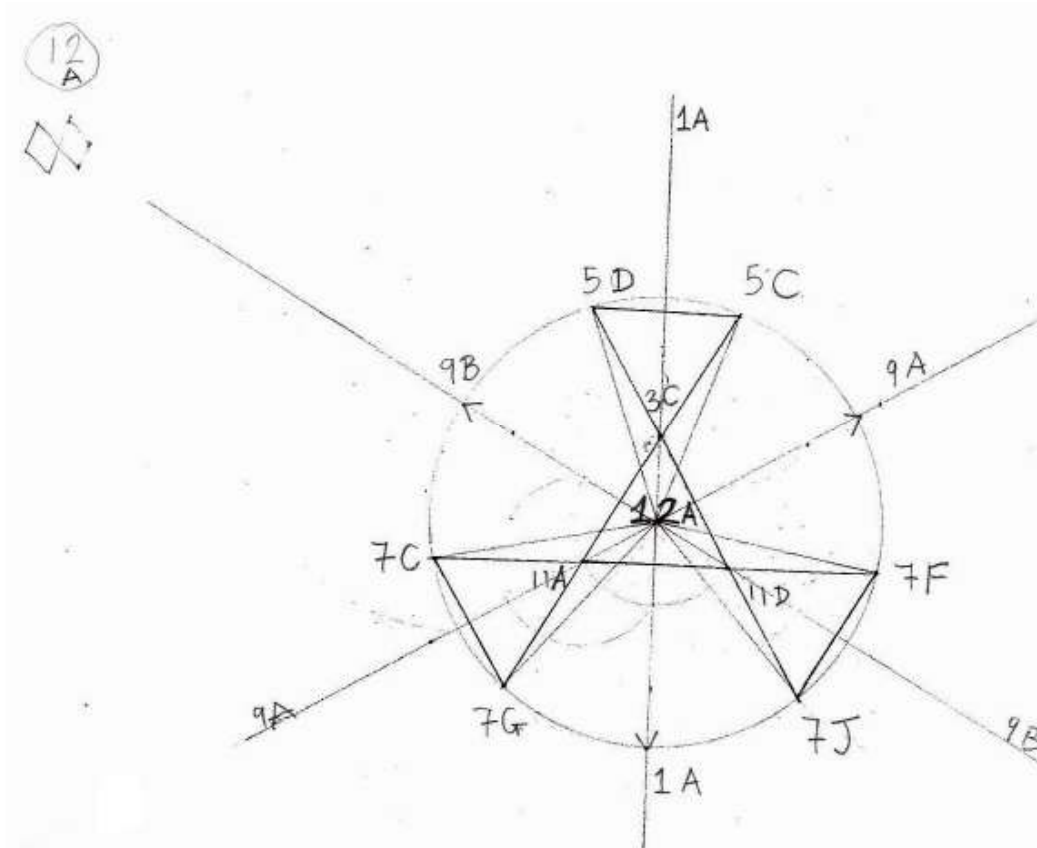

**THE 60 ORIENTATIONS OF THE 12 SIGILS AND THEIR 60x15=900 INTERCONNECTIONS**

	<b>1</b>	<b>2</b>	<b>3</b>	<b>4</b>	<b>5</b>	<b>6</b>	<b>7</b>	<b>8</b>	<b>9</b>	<b>10</b>	<b>11</b>	<b>12</b>	<b>13</b>	<b>14</b>	<b>15</b>	
<b>1A</b>	2A	2B	2C	6A	6B	6C	6D	6E	6F	12A	12A	12B	12B	12C	12C	
<b>2A</b>	1A	2B	2C	3A	3A	5C	5C	5F	5F	6B	6E	11A	11C	11D	11F	
<b>2B</b>	1A	2A	2C	3B	3B	5A	5A	5D	5D	6C	6F	11A	11B	11D	11E	
<b>2C</b>	1A	2A	2B	3C	3C	5B	5B	5E	5E	6A	6D	11B	11C	11E	11F	
<b>3A</b>	2A	2A	4B	4B	4E	4E	5A	5E	10A	10C	10D	10F	11B	11E	12B	
<b>3B</b>	2B	2B	4C	4C	4F	4F	5B	5F	10A	10B	10D	10E	11C	11F	12A	
<b>3C</b>	2C	2C	4A	4A	4D	4D	5C	5D	10C	10E	10B	10F	11A	11D	12C	
<b>4A</b>	3C	3C	4B	4F	5B	5B	5E	5E	7C	7D	7G	7L	8D	9B	10A	
<b>4B</b>	3A	3A	4A	4C	5C	5C	5F	5F	7D	7E	7G	7H	8E	9A	10B	
<b>4C</b>	3B	3B	4B	4D	5A	5A	5D	5D	7E	7F	7H	7I	8F	9B	10C	
<b>4D</b>	3C	3C	4C	4E	5B	5B	5E	5E	7A	7F	7I	7J	8A	9A	10D	
<b>4E</b>	3A	3A	4D	4F	5C	5C	5F	5F	7A	7B	7J	7K	8B	9B	10E	
<b>4F</b>	3B	3B	4A	4E	5A	5A	5D	5D	7B	7C	7K	7L	8C	9A	10F	
<b>5A</b>	2B	2B	3A	4C	4C	4F	4F	5E	6B	6E	7G	7J	8A	8D	12B	
<b>5B</b>	2C	2C	3B	4A	4A	4D	4D	5F	6C	6F	7H	7K	8B	8E	12C	
<b>5C</b>	2A	2A	3C	4B	4B	4E	4E	5D	6A	6D	7I	7L	8C	8F	12A	
<b>5D</b>	2B	2B	3C	4C	4C	4F	4F	5C	6D	6A	7A	7D	8B	8E	12A	
<b>5E</b>	2C	2C	3A	4A	4A	4D	4D	5A	6B	6E	7B	7E	8C	8F	12B	
<b>5F</b>	2A	2A	3B	4B	4B	4E	4E	5B	6C	6F	7C	7F	8A	8D	12C	
<b>6A</b>	1A	2C	5C	5D	6D	7A	7B	7B	7H	7H	7I	8B	8F	11D	11D	
<b>6B</b>	1A	2A	5A	5E	6E	7B	7C	7C	7I	7I	7J	8A	8C	11E	11E	
<b>6C</b>	1A	2B	5B	5F	6F	7C	7D	7J	7J	7K	7K	8B	8D	11F	11F	
<b>6D</b>	1A	2C	5C	5D	6A	7D	7E	7E	7K	7K	7L	8C	8E	11A	11A	
<b>6E</b>	1A	2A	5A	5E	6B	7E	7E	7F	7G	7L	7L	8D	8F	11B	11B	
<b>6F</b>	1A	2B	5B	5F	6C	7A	7A	7F	7G	7G	7H	8A	8E	11C	11C	
<b>7A</b>	4D	4E	5D	6A	6F	6F	7K	7J	8B	8C	8C	10C	10C	11E	12B	
<b>7B</b>	4E	4F	5E	6A	6A	6B	7K	7L	8C	8D	8D	10D	10D	11F	12C	
<b>7C</b>	4A	4F	5F	6B	6B	6C	7G	7L	8D	8E	8E	10E	10E	11A	12A	
<b>7D</b>	4A	4B	5D	6C	6C	6D	7G	7H	8E	8F	8F	10F	10F	11B	12B	
<b>7E</b>	4B	4C	5E	6D	6D	6E	7H	7I	8A	8A	8F	10A	10A	11C	12C	
<b>7F</b>	4C	4D	5F	6E	6E	6F	7I	7J	8A	8B	8B	10B	10B	11D	12A	
<b>7G</b>	4A	4B	5A	6E	6F	6F	7C	7D	8C	8C	8D	10C	10C	11A	12A	
<b>7H</b>	4B	4C	5B	6A	6A	6F	7D	7E	8D	8D	8E	10D	10D	11B	12B	
<b>7I</b>	4C	4D	5C	6A	6B	6B	7F	7E	8E	8E	8F	10E	10E	11C	12C	
<b>7J</b>	4D	4E	5A	6B	6C	6C	7A	7F	8A	8F	8F	10F	10F	11D	12A	
<b>7K</b>	4E	4F	5B	6C	6D	6D	7A	7B	8A	8A	8B	10A	10A	11E	12B	
<b>7L</b>	4A	4F	5C	6D	6E	6E	7B	7C	8B	8B	8C	10B	10B	11F	12C	
<b>8A</b>	4D	5A	5F	6B	6F	7E	7E	7F	7J	7K	7K	9A	10D	11A	11A	
<b>8B</b>	4E	5B	5D	6A	6C	7A	7F	7F	7K	7L	7L	9B	10E	11B	11B	
<b>8C</b>	4F	5C	5E	6B	6D	7A	7A	7B	7G	7G	7L	9A	10F	11C	11C	
<b>8D</b>	4A	5A	5F	6C	6E	7B	7B	7C	7G	7H	7H	9B	10A	11D	11D	
<b>8E</b>	4B	5B	5D	6D	6F	7C	7C	7D	7I	7I	7H	9A	10B	11E	11E	
<b>8F</b>	4C	5C	5E	6A	6E	7D	7D	7E	7I	7J	7J	9B	10C	11F	11F	
<b>9A</b>	4B	4D	4F	8A	8C	8E	10B	10D	10F	12A	12A	12B	12B	12C	12C	
<b>9B</b>	4A	4C	4E	8B	8D	8F	10A	10C	10E	12A	12A	12B	12B	12C	12C	
<b>10A</b>	3A	3B	4A	7E	7E	7K	7K	8D	9B	10C	10E	11A	11A	11B	11F	
<b>10B</b>	3B	3C	4B	7F	7F	7L	7L	8E	9A	10D	10F	11A	11B	11B	11C	
<b>10C</b>	3A	3C	4C	7A	7A	7G	7G	8F	9B	10A	10E	11C	11C	11B	11D	
<b>10D</b>	3A	3B	4D	7B	7B	7H	7H	8A	9A	10B	10F	11C	11D	11D	11E	

**THE 60 ORIENTATIONS OF THE 12 SIGILS AND THEIR 60x15=900 INTERCONNECTIONS**

<b>10E</b>	3B	3C	4E	7C	7C	7I	7I	8B	9B	10A	10C	11D	11E	11E	11F	
<b>10F</b>	3A	3C	4F	7D	7D	7J	7J	8C	9A	10B	10D	11A	11E	11F	11F	
<b>11A</b>	2A	2B	3C	6D	6D	7C	7G	8A	8A	10A	10A	10B	10F	11D	12A	
<b>11B</b>	2B	2C	3A	6E	6E	7D	7H	8B	8B	10A	10B	10B	10C	11E	12B	
<b>11C</b>	2A	2C	3B	6F	6F	7E	7I	8C	8C	10B	10C	10C	10D	11F	12C	
<b>11D</b>	2A	2B	3C	6A	6A	7F	7J	8D	8D	10C	10D	10D	10E	11A	12A	
<b>11E</b>	2B	2C	3A	6B	6B	7A	7K	8E	8E	10D	10E	10E	10F	11B	12B	
<b>11F</b>	2A	2C	3B	6C	6C	7B	7L	8F	8F	10A	10F	10F	10E	11C	12C	
<b>12A</b>	1A	1A	3B	5C	5D	7C	7F	7G	7J	9A	9A	9B	9B	11A	11D	
<b>12B</b>	1A	1A	3A	5A	5E	7A	7D	7H	7K	9A	9A	9B	9B	11B	11E	
<b>12C</b>	1A	1A	3C	5B	5F	7B	7E	7I	7L	9A	9A	9B	9B	11C	11F	

## THE 60 ORIENTATIONS OF THE 12 SIGILS AND THEIR 60x15=900 INTERCONNECTIONS

### Questions:

- What “level” in creation do the 12 sigils and their 60 representations belong to? Are there parallels in scripture, philosophy, or other systems? For instance, in astrology the level of 12 is the zodiac, hence all humans have a sun sign. In Galactic astrology- used by the Astrological Society- the 12 *sigils* are used to symbolize a parallel zodiac where the sun, instead of the earth, is at the centre of the chart. What is the difference between the 12 signs of the zodiac and the 12 *sigils*?
- Could the 12 *sigils* correspond to the level of Plato’s world of ideal forms of which our world is a mere shadow? How do our personal ways of perceiving identities in the world correspond to the 60 representations of the 12 *sigils*?
- In Gurdjieff’s philosophy, does the level of 12=60 correspond to *Tritocosmos (Man=48)*?
- How do we observe and identify such patterns in ourselves and the world around us?
- Are the 60 *sigil shapes* associated with specific beings or aspects of one being?
- What does the rule of *pair-swapping* signify really? Is it similar to the I Ching system of divination, which gives rules on how *yin* can change into *yang* and vice versa?
- What is happening to the structure that holds the three forces together when we imagine that two constructors swap places? Geometrically, the constructor’s sequence is fixed because they are the result of the directions of the 3 forces. So, how can they possibly swap places?
- According to Saros philosophy, apart from the rule of *pair-swapping* there is also one additional rule through which one sigil can change into another. This happens when one sigil *interprets* or views another sigil according to its own internal pattern. There are 3,600 possible ways of this happening\*, (60x60) and these are said to be the relative viewpoints we have of one another.
- But if we can invent such logical rules as the above, there could be many more rules. The question is: to what end?

Byron Zeliotis  
Winter Solstice 2019

\* “A SAROS of images”, according to “The Book of Jubilee” ©Saros. Cranswick Press